

Testing of Rigid Cellular Thermal Insulation as per Indian Standards

N K Shah

Assistant Professor
Mechanical Engineering Department
Nirma University, Ahmedabad, India
E-mail: niraj.shah@nirmauni.ac.in

Arpit Parekh

Executive Engineer
L & T Chiyoda Ltd.
Vadodara, India
E-mail: parekharpit@yahoo.com

S V Jain

Assistant Professor
Mechanical Engineering Department
Nirma University, Ahmedabad, India
E-mail: sanjay.jain@nirmauni.ac.in

Rohit Patel

Assistant Professor
Mechanical Engineering Department
L. C. Institute of Technology, Bhandu, India
E-mail: patelrohit@yahoo.com

Abstract— Thermal Insulations play a great role in keeping the flow of energy from hot to cold bodies to a minimum. Quality and effectiveness of thermal insulation is of prime importance and unless the properties of insulation are evaluated there is little chance of improvement of their performance. It is essential that properties of insulations be evaluated for acceptability according to national and international standards. In the present study, various tests were performed on Rigid cellular insulation (Thermocol) as per IS 11239 to determine the temperature at which the insulation get distorted as well as to study its characteristics when the insulation get ignited in vertical as well as horizontal positions. The statistical analysis of experimental results was carried out at 95 % confidence level for all the tests and the % error in various parameters was found to be within ± 1 to 3%. The findings of the present study may be helpful to the researchers, manufacturers and industries dealing with the similar insulating materials.

Keywords—Rigid cellular; Thermocol; distort; statistical analysis

I. INTRODUCTION

Energy resources are depleting and demand is increasing day by day. One of the ways to utilize available reserves effectively is energy conservation. The insulation, defined as the material which retards the heat flow with reasonable effectiveness, play very crucial role in energy conservation. To understand the fundamentals of thermal insulation, it is required to know the fundamentals of heat transfer. The modes of heat transfer are:

- Conduction (molecule to molecule transfer of kinetic energy)
- Convection (transfer of heat by physical moving the molecules from one place to another)
- Radiation (transfer of heat through electromagnetic waves)

There are two basic functions of Insulation (a) to prevent the flow of heat from the system to surroundings (as in the case of steam and hot water pipes which are used in power

plants) and (b) to prevent the flow of heat from the surrounding to the system (as in case of air conditioning, refrigeration and cryogenics.)

The details of main types of insulations used by various industries are given in Table I.

TABLE I. TYPE OF INSULATION WITH EXAMPLES

Types	Examples
Blankets: Batts and rolls	Fiber glass, Mineral wool, Natural Fiber, Plastic fiber
Foam Board or Rigid Foam	Polystyrene, Polyiso, Polyurethane
Loose-Fill	Cellulose, Fiber glass, Mineral wool
Reflective Insulation	Foil Faced Craft paper, Plastic film
Sprayed foam and Foamed-in-place	Cementitious, Phenolic, Polyisocyanurate

Purpose of providing thermal insulations are energy saving, process control, personal protection, fire protection, sound attenuation and aesthetics. For thermal insulations properties like thermal resistance, apparent thermal conductivity, density, surface burning characteristics, compressive resistance, thermal expansion/contraction, dimensional stability, water vapour permeability, corrosion resistance, fire resistance, moisture absorption etc are important to decide its performance [1].

The applications of thermal insulations includes air-conditioning systems, refrigerants and food preserving stores, preservation of liquid gas, power plants, heat exchangers, insulating bricks in all types of furnaces, residential and commercial buildings, process industries, pharmaceutical plants, domestic applications, space and cryogenic applications etc.

The selection of insulation depends on the temperature range, type of application, cost of insulation etc. Among various insulations Rigid cellular insulation finds wide applications in domestic and commercial applications due to various advantages associated with it like low cost, less weight, ease of availability, large temperature range etc. In the present study, the information about experimental

setups required to conduct few selected tests for Rigid cellular insulation are given. The details of testing of Rigid cellular insulation carried out at Nirma University, Ahmedabad are presented.

II. TESTING OF RIGID CELLULAR INSULATION AS PER IS: 11239 (PART I TO 13)

Various types of insulations are available in market.. To rate these insulations, it is necessary to know its performance under various conditions. Various IS are available to know their properties which in turn gives idea about their performance, effectiveness and quality. For Rigid cellular insulation following tests shall be conducted as per IS 11239:

- 1) Determination of dimensions
- 2) Determination of apparent density
- 3) Determination of dimensional stability
- 4) Determination of water vapour transmission rate
- 5) Determination of volume percent of open and closed cells
- 6) Determination of coefficient of linear thermal expansion
- 7) Determination of heat distortion temperature
- 8) Determination of flame height, time of burning and loss of mass
- 9) Determination of water absorption
- 10) Determination of flexural strength
- 11) Determination of compressive strength
- 12) Determinations of horizontal burning characteristics
- 13) Determination of flammability by oxygen index

In the present study, tests mentioned in (6), (8) and (12) are presented.

III. EXPERIMENTAL SETUPS FOR TESTING OF RIGID CELLULAR INSULATIONS

In this section, the setups used to perform particular tests are discussed.

A. Setup for Determination of Heat Distortion Temperature as per IS: 11239 (Part 6) – 1985[2]

This test is used for initial screening of Rigid cellular thermal insulation. The temperature at which a cantilever test specimen under loaded conditions deforms by specified amount when its temperature is raised at a uniform rate is called heat distortion temperature. The main components of the setup are:

- a) The circulating hot air oven in which a linear temperature rise of $50 \pm 1^\circ\text{C/h}$ can be maintained such that temperature in the vicinity of the test specimen is uniform to within $\pm 2^\circ\text{C}$.
- b) A clamp to support the test specimen horizontally inside the oven.
- c) Weights and weigh holder such that a mass of 10 ± 0.1 gm can be attached to the free end of test specimen.
- d) An indicating device consisted of two pointers at a vertical distance of 10 mm.

The schematic diagram of experimental setup is shown in Fig. 1 and the views of the setup and hot air oven are shown in Fig. 2.

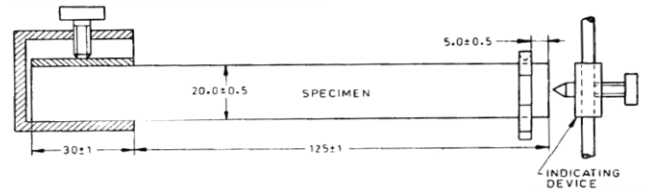

Figure 1. Schematic diagram of the setup



Figure 2. View of test setup (left) and hot air oven (right)

B. Setup for Determination of Flame Height, Time of Burning and Loss of Mass as per IS 11239 (Part 8): 1985[3]

This test is used for comparing relative extent and time of burning and loss of mass of Rigid cellular thermal insulation materials. In this test, the specimen is mounted in a vertical chimney with a glass front and ignited with a Bunsen burner from the bottom for ten seconds. The height and duration of flame and the mass percent retained by the specimen are recorded.

The main components of the setup are:

- a) Test Chimney: The body of the chimney is made up of stainless steel. An insert made of 0.025 mm aluminium foil is fastened on the inner surface of chimney. A heat-resistant glass panel is provided at the front of the chimney.
- b) Specimen support: To support the specimen a stainless steel channel carrying three pins was used. The schematic diagrams of test chimney and specimen support are shown in Fig. 3.
- c) Burner - A standard gas burner with 9.5 mm inside diameter barrel capable of producing a flame with an inner cone temperature of 960°C was used to ignite the specimen
- d) Aluminium weighing dishes: Disposable aluminium weighing dishes of 50 mm diameter were used to collect the dripping polymer.
- e) Fume cupboard: The test chimney was placed inside a relatively draught-free fume cupboard which helps in discharge of gases coming out while performing the test. The views of fume cupboard and test chimney are shown in Fig. 4.
- f) Timer - To determine the duration of burning timer capable of measuring to the nearest 0.1 s was used.
- g) Weighing balance - To weigh the specimen weighing balance capable of weighing to the nearest 0.01 g was used.

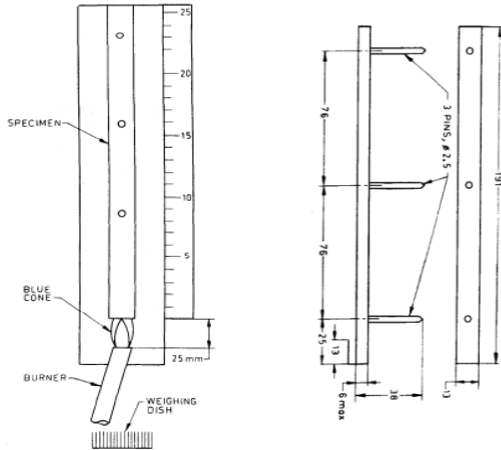

Figure 3. Schematic of test chimney (left) and specimen support (right)



Figure 4. View of fume cupboard (left) and test chimney (right)

C. Setup for Determinations of Horizontal Burning Characteristics as per IS 11239 (Part 12): 1988[4]

This test is used to compare the relative horizontal burning characteristics of Rigid cellular thermal insulation materials by exposing the specimen to low energy source of heat. The characteristics measured by this test may be affected by density and anisotropy of the cellular materials and the thickness of the specimen. The main components of the setup are:

- Test chamber: A test chamber (inside dimensions: 600 mm length, 300 mm width and 760 mm height) made up of galvanized iron sheets was used. On the inner sides of test chamber, asbestos insulating board was provided. It was placed inside the fume cupboard to have draught free and natural air circulation around the specimen during the test.
- Fuel supply: To burn the insulating material LPG gas was used with pressure regulating and on/off valves.
- Burner with wing top: A standard gas burner with 9.5 mm inside diameter was used. A wing top having an opening of internal length 48 mm and internal width 3 mm was fitted on the burner.
- Specimen support gauze: The specimen support (215 mm long, 75 mm wide and having 13 mm of its

length bent to form a right angle) consisted of 6.4 mm mesh gauze, 0.8 mm diameter steel wire was used.

- Gauze Holder - The gauze holder made up of mild steel was kept with its long axis horizontal and parallel to the 600 mm dimension of the test
- Timing Device - A timing device accurate to within ± 1 second was used.
- Measuring Scale - A measuring scale graduated in millimetres was used.

The schematic diagrams of test chamber and gauze holder are shown in Fig. 5 and the views of test chamber and gauze holder (when specimen is burning) are shown in Fig. 6.

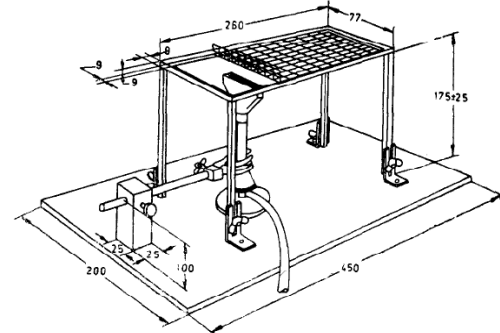
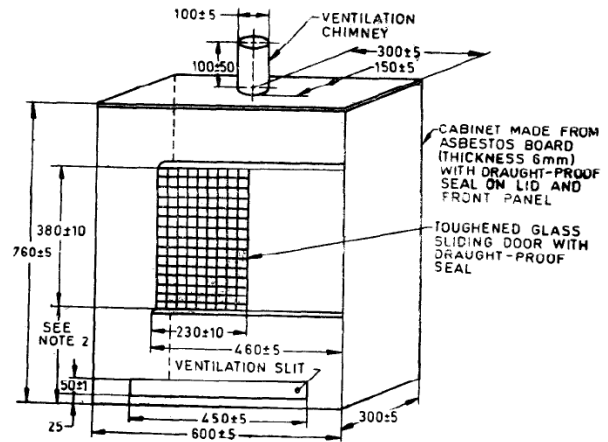

Fig. 5 Schematic diagram of test chamber (left) and gauze holder (right)

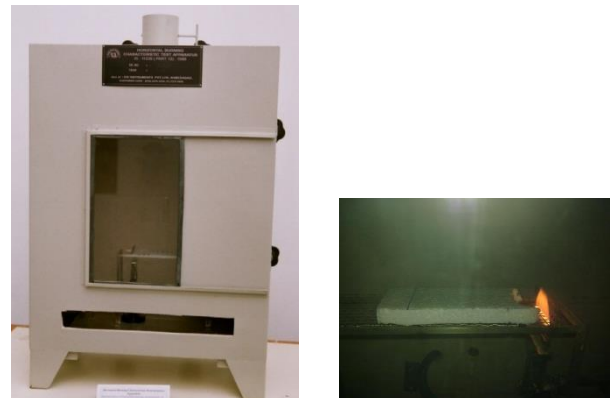

Fig.6 View of test chamber (left) and gauze holder (right)

IV. RESULTS AND DISCUSSION

In this section test procedures and results for different tests are discussed.

A. Determination of heat distortion temperature

The procedure of performing this experiment is given below:

- a) Three test specimens of size $155 \times 20 \times 20$ mm thick were cut from Rigid cellular insulation (Thermocol) sheet in the form of rectangular bars.
- b) The test specimen was conditioned at $27 \pm 2^\circ\text{C}$ and 65 ± 5 percent relative humidity for 16 hours in a conditioning chamber.
- c) One of the test specimens was clamped horizontally inside the oven such that there was no significant deformation of the cell structure and the effective length of the cantilever was kept as 125 mm.
- d) A mass of 10 g was attached at a distance of 5 mm from the free end of the test and the indicating device was adjusted such that the deflection of the free end of the test specimen can be noted.
- e) Then the temperature of the oven was raised at a uniform rate of 50°C/h which was measured by measuring the air temperature adjacent to the test specimen with thermocouple.
- f) When the free end of the test specimen was dropped by 10 mm as referred by the indicating device, the temperature of the air surrounding the specimen was recorded which is considered as the heat distortion temperature of the specimen.
- g) Similarly other two specimens were tested.
- h) The above procedure was repeated six times to carry out statistical analysis of experimental results and the average of six readings is given in Table II.

TABLE II. OBSERVATIONS

Specimen no.	Temperature ($^\circ\text{C}$) correspond to 10 mm deformation
1	95.4
2	95.1
3	95.5

From the experiments, the average temperature correspond to 10 mm deformation was found to be 95.33°C . The statistical analysis of experimental results was carried out at 95 % confidence level and the % error in temperature was found to be within $\pm 1.46\%$.

B. Determination of Flame Height, Time of Burning and Loss of Mass

The procedure of performing this experiment is given below:

- a) Six test specimens of size $250 \times 20 \times 20$ mm thick were cut from Rigid cellular insulation (Thermocol) sheet in the form of rectangular bars.

- b) The test specimen was conditioned at $27 \pm 2^\circ\text{C}$ and 65 ± 5 percent relative humidity for 16 hours in a conditioning chamber.
- c) The mass of all the specimens (W), specimen support (S) and the disposable weighing dish (D) with a least count of 0.01 g were recorded.
- d) The burner was ignited and adjusted such that the height of inner blue cone was 25 to 35 mm and the temperature at the top of the inner cone was $960 \pm 10^\circ\text{C}$.
- e) The specimen was placed on the three pins of the specimen support such that the top of the specimen remain even with the top of the specimen support.
- f) The glass front was put in place and the specimen was ignited by placing the inner cone of the burner flame under the centre of the specimen for 10 seconds.
- g) By keeping the burner at an angle of about 15° from the vertical the maximum flame height (H) was recorded to the nearest 10 mm.
- h) When the combustion of the specimen ceased, the timer was stopped and the time was recorded as the time to extinguishment (T) to the nearest second.
- i) After cooling, the specimen support and specimen were removed and its combined weight was recorded as (S).
- j) The disposable weighing dish containing the droppings was weighted and recorded as (D).
- k) Similarly other five specimens were tested.
- l) The above procedure was repeated six times to carry out statistical analysis of experimental results and the average of six readings is given in Table III.

The percentage mass retained (PMR) by the specimen was calculated as:

$$\text{PMR} = \frac{(S_2 - S_1) + (D_2 - D_1)}{W} \times 100 \quad (1)$$

From the experiments, the average values of maximum flame height, time of burning of specimen and the percentage mass retained by the specimen were found to be 198 mm, 49 s and are 83.47% respectively. The statistical analysis of experimental results was carried out at 95 % confidence level and the % error in determination of maximum flame height, time of burning of specimen and the percentage mass retained by the specimen were found to be $\pm 2.12\%$, $\pm 1.62\%$, $\pm 2.88\%$, respectively.

C. Determinations of Horizontal Burning Characteristics

The procedure of performing this experiment is given below:

- a) Ten test specimens of size $150 \times 50 \times 10$ mm thick were cut from Rigid cellular insulation (Thermocol) sheet in the form of rectangular bars. All the test specimens were marked across its width at a distance of 25 mm from one end, which are referred as gauze mark.
- b) The test specimen was conditioned at $27 \pm 2^\circ\text{C}$ and 65 ± 5 percent relative humidity for 16 hours in a conditioning chamber.

- c) While performing the test, the test chamber was placed in the fume cupboard such that its fan is off and chamber lid is closed. The burner and gas pressure was adjusted such that the height of visible portion of a blue flame remains 38 mm.
- d) The specimen support and the gauze holder were placed in a test chamber such that the lower surface of the specimen remains 13 mm above the tip of the burner wing top.
- e) The test specimen was placed on the support in such a manner that the end farthest from the gauze mark is touching the 13 mm bent up portion of the support gauze.
- f) The gas was ignited and simultaneously the timing device was started. The severity of the burning characteristics of the specimen was observed and recorded in terms of warping, charring, melting, dripping and whether any drips continue to burn on reaching the floor of the chamber.
- g) The gas supply was stopped after 60 seconds. The time was recorded when the specimen flame reached the gauze mark or when the specimen flame extinguished.
- h) Similarly other nine specimens were tested.
- i) The above procedure was repeated six times to carry out the statistical analysis of experimental results and the average of six readings is given in Table IV.

From the experiments, the average extent of burning, extinction time and burning rate were found to be 30.8 mm, 41.9 s and 2.85 mm/s respectively. Also while burning, warping of specimen was observed. The statistical analysis of experimental results was carried out at 95 % confidence level and the % error in determination of extent of burning and extinction time were found to be $\pm 1.60\%$ and $\pm 2.80\%$ respectively.

V. CONCLUSIONS

In the present study, three tests were performed on Rigid cellular insulation (Thermocol) as per IS 11239. The conclusions drawn from the study are as under:

- ❖ From heat distortion test, the average temperature for 10 mm deformation of the specimen was found to be 95.33 °C
- ❖ While burning the specimen in vertical position, the average values of maximum flame height, time of burning of specimen and the percentage mass retained by the specimen were found to be 198 mm, 49 s and are 83.47% respectively.
- ❖ From the study of horizontal burning of specimen, the average extent of burning, extinction time and burning rate were found to be 30.8 mm, 41.9 s and 2.85 mm/s respectively. Also while burning, warping of specimen was observed.

The statistical analysis of experimental results was carried out at 95 % confidence level for all the tests and the % error in various parameters was found to be within ± 1 to 3%. The findings of the present study may be helpful to the researchers, manufacturers and industries dealing with the similar insulation materials.

REFERENCES

- [1] R. T Bynum, Insulation Handbook, Mc-Graw-hill Publication,
- [2] IS 11239 (Part 6), "Methods of Test for Rigid Cellular Thermal Insulation Materials – Heat Distortion Temperatures", 1985.
- [3] IS 11239 (Part 8), "Methods of Test for Rigid Cellular Thermal Insulation Materials – Flame Height, Time of Burning and Loss of Mass", 1985.
- [4] IS 11239 (Part 12), "Methods of Test for Rigid Cellular Thermal Insulation Materials – Horizontal Burning Characteristics", 1988.

TABLE III. OBSERVATIONS AND RESULTS

Specimen no.	Weight of specimens (W), g	Maximum flame height (H), mm	Time to extinguishment (T), s	Mass of specimen support (S1), g	Mass of weighing dish (D1), g	Mass of support and specimen after burning (S2), g	Mass of dish and burn material (D2), g	PMR (%)
1	1.18	200	59	128.40	120.78	128.85	121.4	90.68
2	1.27	200	39			128.9	121.31	81.10
3	1.08	150	41			128.88	121.28	90.74
4	1.22	190	44			128.9	121.27	81.15
5	1.29	240	57			128.9	121.22	72.87
6	1.21	210	54			128.76	121.44	84.30
Average		198.33	49					83.47

TABLE IV. TABLE 4: OBSERVATIONS AND RESULTS

Specimen no.	Mass of specimen (g)	Length of remaining specimen after burning (mm)	Time of extinguishment (s)	Rate of burning = (length of remaining specimen after burning/time of extinguishment) (mm/sec)
1	0.95	117	45	2.60
2	1.13	119	45	2.64
3	1.14	117	43	2.72
4	1.02	122	40	3.05
5	1.07	119	39	3.05
6	0.98	120	40	3.00
7	1.11	118	42	2.81
8	1.06	123	45	2.73
9	1.12	116	39	2.97
10	1.03	121	41	2.95
Average		119.2	41.9	2.85