

Simulation and Hardware implementation of protection system for high power inverters using FPGA controller

Harshil shah¹, Prof.Swapnil.N.Jani², D.M.Choudhary³

Abstract—These topic illuminates to develop the protection system for high power inverters using FPGA(field programmable gate array) software. The current system consist of thyristor for the high power inverters and according to the simulation results hardware implementation is done with FPGA controller board. For the reference values for FPGA code generation, one power circuit can be developed with ZCD circuit, according to the result of the power circuit FPGA controller will work in such a way that if any fault occurs in the system then the system will be protected. FPGA board can be interface with the hardware and in software of FPGA program can be developed for the feedback of the protection system. However the system which can be developed in hardware or power circuit can be modify also with other power ratings and according to that FPGA controller will work and the system for the protection of the high power inverters can be easily implemented.

I. INTRODUCTION

By designing the particular topology it is easy to obtain design simulation results and also by observing all the faults and all the parameters making close loop control system with the help of the microcontroller and the controller circuit with protection system of this high power inverter is implemented and then hardware system of this power module is implemented. Basically in this system thyristor based circuit is being used and protection of that system is developed so during supply process as input voltage is given with that one IGBT switch is also being used to give opposite supply to DC link to compensate harmonics and with using logical elements thyristor pulse is given so that we can get voltage across the thyristor and output voltage waveforms to develop protection system using FPGA within limit and snubber circuit and sharing resistor are also to be added to the circuit for better output results.

Harshil Shah¹/S.N.Jani²
Institute of technology/ Nirma University
India

D.M.Choudhary³
Electrotherm India Pvt Ltd
India

II. HIGH POWER INVERTERS

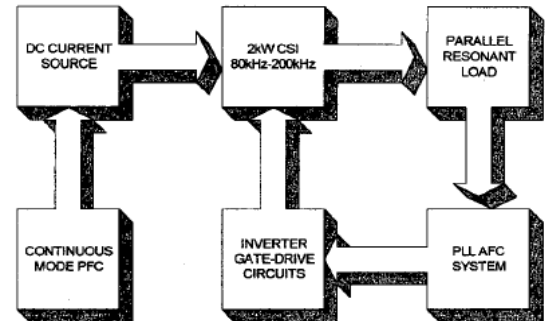

Fig. 1. Block diagram configuration.

A. Proposed Topology

Basically in this high power inverter module, voltage level should be maintained so that other fault level can be decreased. According to parallel load connection, inverter gate drive circuits will change pulse for the thyristor.

We can simulate this inverter circuit in single phase and three phase also. In controller section FPGA is used so that particular limit for the peak value should be decided and according to that if fault goes above or below that limit the whole circuit will open so that components used in the circuit will be safe and protection of circuit can be easily developed.

Without use of snubber circuit, spikes in the voltage and distortion in the current waveforms can clearly notify and that can be minimized only by adding snubber circuit. Sharing resistor are also to be added in the circuit for the balancing of voltage levels. Voltage monitoring and digital control system can be used also but FPGA is more user friendly than all other controller systems in recent days.

Basically the model of the circuit consist of thyristor as a semiconductor devices and RL load. Gating pulse are obtained according to load changes and with the reference of that particular load, load voltage waveforms are being obtained which is given to the comparator and from that with using IGBT switch and logical elements pulses are given to the pairs of thyristor accordingly via comparator. One thing is also to be noticed that main supply is given to the load side for the load voltage waveforms and another DC supply is given by the IGBT switch to the load side from the opposite side of main supply. The main reason of giving this supply is to eliminate harmonics and this IGBT switch is on for only 500us and after that this system doesn't affect to the output voltage

III. SIMULATION RESULTS

waveforms. The pulses which are given to the thyristor have been given 0.2V DC source and being compared with the values of load side then output of the comparator is given to the thyristor gate pulses.

The values of the load side, in which capacitor values are varies between 100uf and values of an inductor are varies between 65uH-80uH. The inductor which are being used for the filtering have values of 7uH. Waveforms across all the thyristor are obtained for the analysis and according to that parameters are decided for the FPGA controller.

B. Controller development

The system which is being generated as a protection of the inverters are being controlled by variable parameter blocks in the FPGA. In that it is easy to set particular limits with close loop for the fault and as soon as any fault or trouble occurs the controller can manage the protection of the thyristor and other components so that the whole circuit will be safe within the limits.

According to the pin diagram of FPGA controller, it is easy to enter the values of the different section for the varying output and it is also user friendly than the DSP which is being used for the controller.

Programming and code generation in the FPGA is according to the fault level and other parameters which are being changed during fault according to the system.

FPGA Cyclone controller consist of ADC, DAC, Buffer and some other ports are there for the analysis of the protection system for high power inverters.

Here in Fig. 2 shows the voltage waveform across the thyristor and here in this system in single phase four thyristor are connected in one lag, it means two thyristors are in series in one lag so during positive half cycle four thyristor will conduct and negative half cycle other four thyristor will conduct in single phase system. Here the same voltage across thyristor waveforms we can get in hardware also which can be taken as a reference for the controller section. If we are using two thyristor are in series then the results of that two thyristor will be almost same because they are blocking same voltage but the voltage will get divide so as many thyristor used in a system we can say that the voltage will get balanced, so the load or stresses on each thyristor will get reduced.

So according to the simulation and hardware results are being observed. By changing the parameters current and output voltage waveforms can also be varied.

Here in Fig. 3 shows the output voltage waveforms of the system, basically here output voltage waveform should be pure sinuswave and it describe the system without any fault or losses. Basically this output voltage waveforms are pure sinusoidal and which can be obtained by using LC filter also if harmonics or spikes are there. Here in Fig. 4 shows the current waveforms through the system and according to charging and discharging mode, positive and negative cycle, waveforms to be obtained.

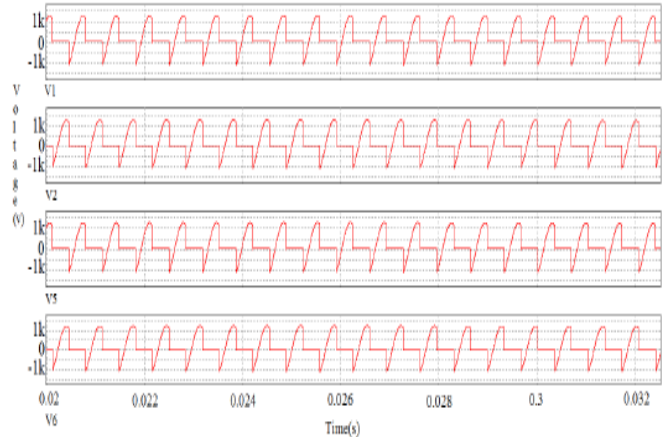

Fig. 2. Voltage across thyristor

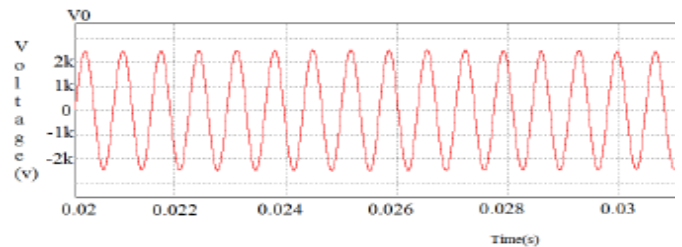

Fig. 3. Output voltage waveforms

Basically during operation periods, voltage across the thyristor which are shown in Fig.2 are due to inductive load so during positive half cycle, it slightly goes below zero due to inductive load and current which are shown in Fig.4 is depend on load which are connected. So according to the calculation of parameter, voltage and current waveforms can be varied as load changes. Other thing is to be consider as a power factor balancing, PF is maintained throughout the system nearer to unity as much as possible to get desired values so here we are getting PF is around 0.95 which very much nearer to the unity and that shows the ratio of low losses in the system. PF should be in proper manner.

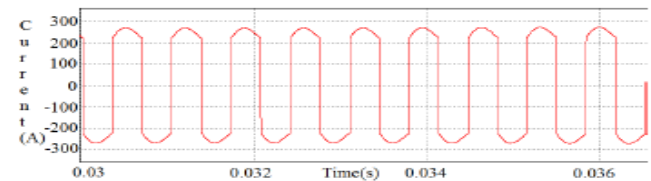

Fig. 4. Current waveforms

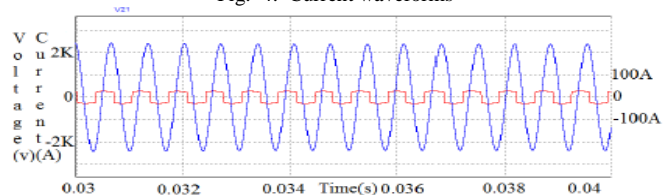

Fig. 5. Voltage and Current waveforms

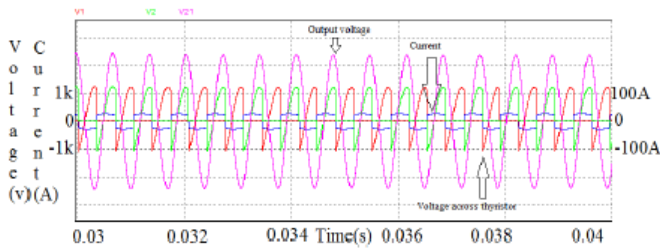

Fig. 6. Voltage and Current waveforms

Here Fig.5 shows the voltage and current waveforms together and Fig.6 shows the voltage, current and voltage across thyristor waveforms of both positive and negative half cycle. Here we can observe many things and most importantly PF which shows 0.95 value. The hardware results we are getting are same as the simulation results of voltage across thyristor, current, output voltage waveforms etc.

Thus it is easy to interphase this simulation results with FPGA controller and according to this simulation results limits for the protection system to be developed in such a way that the whole inverter of high power should be protected. Here limit for each of the parameter is created in FPGA so that values goes above or below that value the controller works and gives feedback. So according to that whole system is protected.

IV. HARDWARE DESCRIPTION

Here basically in hardware implement, one power circuit with ZCD is developed and the values with parameters like voltage across thyristor, current in the system, reactance, impedance, capacitance etc should be measured and with taking the reference values of this parameters, power circuit is being developed.

A. ZCD circuit

Hardware should be in such a way that simulation results which we have obtained are very much similar to the hardware results.

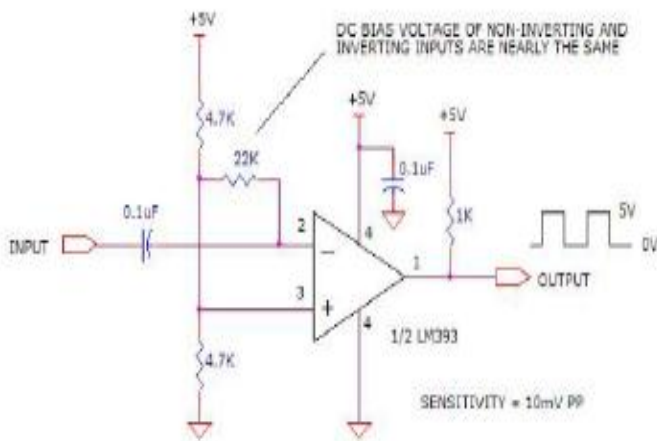

Fig. 7. ZCD circuit

Here in Fig. 7 shows the ZCD circuit that can be used in a power circuit to get the result of the parameters so that it can be used as reference for the FPGA controller limit code generation.

The values we can see that LM393 is the regulator IC which can easily balance the voltage levels, capacitors with the values of 0.1uF are used with at least 5V rating. Resistors used here are 4.7K, 22K, 1K values. Basically output port of LM393 gives square wave signal as zero crossing detector circuit. Basically we want 5V output to give controller so from transformer we will supply to ZCD circuit and from ZCD we will get 5V detected output which will given to the controller section.

Here in Fig. 8 it shows the block diagram of a power circuit which is being used for the FPGA Controller reference.

B. Power circuit

ZCD produce narrow pulses to every zero crossing point, its pulses are applied to the port of a FPGA controller. The output of this is ANDed with astable output of 555 as a high frequency signal. And output of AND gate will be through amplifier & pulse transformer send to SCR gate.

Reference values which can be generated by the analysis of power circuit can be modify also by varying the values in power circuit as well as ZCD output analysis. The waveforms which we are getting in this power circuit in oscilloscope are similar to the simulation results, according to that limits in FPGA controller can be decided and programme for the close loop feedback is generated.

And we can also say that this whole system can be implement in high rating also for the protection of the system in some industry or somewhere. Programming in FPGA CONTROLLER is the heart of this implement of the system because all the analysis of feedback and other parameters are depend on the controller section.

Here in Hardware, ADC and DAC are used in controller section to get signal accordingly. They are designed to operate from single +5V supply with +10V multiplying referances for 4-quadrant output with 6.8 MHz bandwidth. The 4-quadrant resistors facilitate resistance matching and temperature tracking, which minimize the number of components needed for multiquadrant applications.

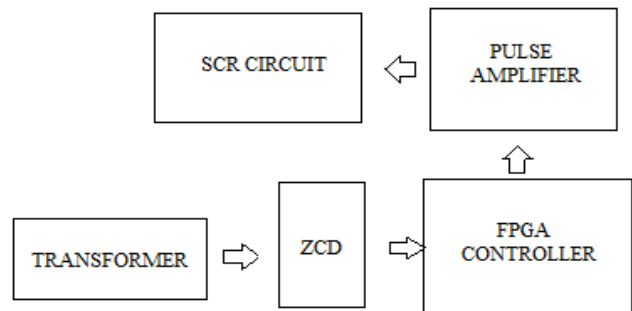

Fig. 8. Power circuit block diagram

AD7671 plays an important role to ensure such parameters as signal-to-noise ratio(SNR) and total harmonic distortion(THD), in addition to the more traditional dc parameters of gain , offset, and linearity. It features a very high sampling rate mode , a fast mode for asynchronous conversion rate applications, and for low power applications, a reduced power mode(impulse) where the power is scaled with the throughput.

In power circuit basically IC can be also varied by different topology varies because we want +5V output as ZCD accordingly, so by switch to other topology we can also get +5V output and according to the power circuit works.

V. FPGA CONTROLLER

FPGA controller is a field programmable gate array controller which works as DSP. Other useful parts are connected with the controller for the proper output.

A. Block diagram analysis

For the analysis of the system, program of FPGA CONTROLLER provides the feedback for the system which is used to minimize losses as system goes into faulty condition. Program of FPGA CONTROLLER is the heart of the system for protection or other parameters development. FPGA is more user friendly than the DSP. FPGA controller is also being used as a controller for the protection system development

Here Fig. 7 shows the block diagram of the FPGA controller in which flash memory, LCD, power measure ports are there for the analysis. These ports and components are very much useful for the system development itself because it considers all the parameters without fault and it minimize the losses.

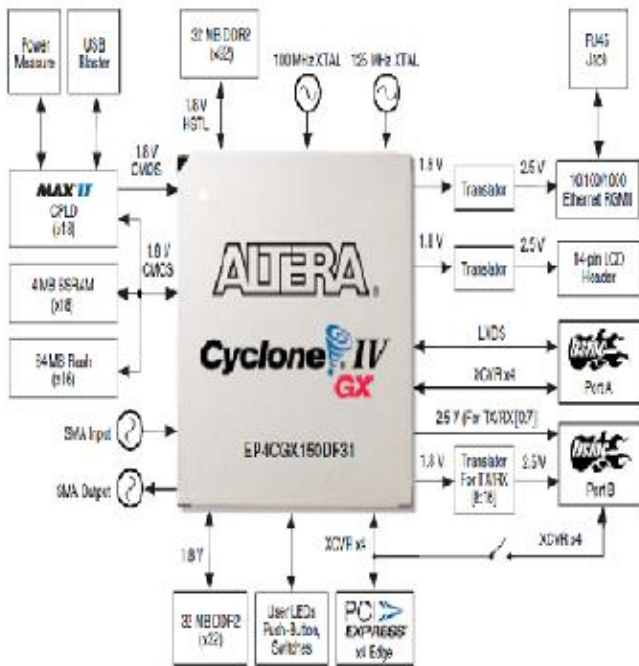

Fig. 9. FPGA controller

Basically the board includes many components system controller which interfaces directly to the configuration , LCD control, power monitoring control and other purposes. The system controller contains the required state machine and control logic to determine the configuration source for the controller. For the programming of the controller for one particular system, programming is possible through a serial flash loader and by performing in system programming through the AS programming header. Here FPGA configuration can be done by external USB-Blaster also. The processor of the FPGA can decompresses the bit stream in real time and programs its SRAM cells.

B. Pin configuration analysis

The pin which is being used in the development for the protection system is the CYCLONE FPGA 2C35. Generally all the components are being operated by this pin. Compressed and uncompressed configuration of data in same program file is possible. Basically compression can be done by enabling bit streams in convert program files. During the system power up, both cyclone FPGA and serial data configuration device enter into a power-on reset mode. The value of the pull-up resistors on I/O pins Can be varies according to the DC switching. The clock pulses which can be generated by the cyclone FPGA controls the entire configuration of the protection system for the high power inverters.

basically this FPGA uses 10-MHZ internal oscillator by default to initialize the different values of the parameters. Configuration of multiple devices in a cascading manner is also possible by using a single serial port.

Here Fig.8 shows the pin diagram of FPGA controller in which flash, SDRAM, SRAM, 7-segment display, toggle switch, pushbutton switch, LED pins are there. In these system, interphase between hardware components and FPGA controller is done and according to the fault occurs the controller gives feedback. Here basically limits are provided during code generation and programming in FPGA controller. It is easy to obtain hardware results after getting simulation results.

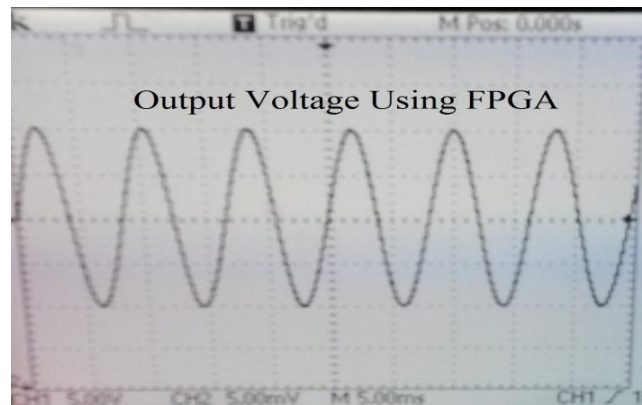

Fig. 10. Output Voltage Waveform Using FPGA Controller

(Scale X:axis:1 Div = 5.00ms, Y: axis: 1 Div = 5.00 V)

Thus the whole protection system can be implemented using simulation and FPGA controller for high power inverters and analysis and development can be done.

CONCLUSION

Here from this concept we can conclude that protection system for the high power inverters can be implemented by sensing the voltage across thyristor, snubber voltage and current waveforms in FPGA Controller and according to that result hardware system is also being implemented.

ACKNOWLEDGMENT

The authors gratefully acknowledge the support of the Electrotherm India, Ahmedabad in the development of the system and also the support of the Nirma University Ahmedabad for platform.

REFERENCES

- [1] International Journal of Emerging Science and Engineering (IJESE) ISSN: 2319-6378, Volume-1, Issue-5, March 2013. Design of Snubber Circuit for Thyristors Using Pspice by Nancy Merin Thomas.
- [2] T. M. Undeland, F. Jensen, A. Steinbakk, T. Rogné, and M. Hemes, "A snubber configuration for both power transistors and GTO PWM inverters," in *Con\$ Rec. 1984 IEEE Power Electron. Specialist Con\$ (PESC)*, pp. 42-53.
- [3] I. Khan, J. Tapson and I. De Vries, "Automatic Frequency Control of an Induction Furnace", *Proc. IEEE Con\$, A@icon '99*, v01.2, September 1999, pp. 913-916.
- [4] J. M. Ho and F. C. Juang, "4 Practical PWM Inverter Control Circuitry for Induction Heating and Studying of the Performance under Load Variations", *Proc. IEEE Con\$ International Symposium on Industrial Electronics*, vol. 1, July 1998, pp. 294-299.
- [5] F. Blaabjerg, R. Teodorescu, M. Liserre, and A. V. Timbus, "Overview of Control and Grid Synchronization for Distributed Power Generation Systems," *IEEE Trans. Ind. Electron.*, Vol. 53, pp. 1398-1408, Oct.2006.
- [6] J. Satry, O. Ojo, and Z. Wu, "High-performance control of a boost ACDC PWM rectifier/induction generator system," *IEEE Trans. Ind. Appl.*, vol. 42, no. 5, pp1146-1154, Sept./Oct., 2006.
- [7] Nancy Merin Thomas "International Journal of Emerging Science and Engineering (IJESE)" ISSN: 2319-6378, Volume-1, Issue-5, March 2013.
- [8] A Large-Capacity GTO Inverter with Low-Loss Snubber Circuits. N. Kawakami, S. Ueda, *Member, IEEE*, M. Hombu, *Senior Member, IEEE*, A. Ueda, *Member, IEEE*, and Y. Jifuku. *IEEE TRANSACTIONS ON INDUSTRY APPLICATIONS*, VOL. 29, NO. 6, NOVEMBER/DECEMBER 1993.
- [9] Short-circuit protection for three phase power inverters,

International IOR rectifier, the power management leader.

[10] Design of snubber circuit of thyristor using Pspice, **International Journal of Emerging Science and Engineering (IJESE) ISSN: 2319-6378, Volume-1, Issue-5, March 2013.**

[11] Digital-Controlled Single-Phase Transformer-Based Inverter for Non-Linear Load Applications Ming-Shi Huang, *Member, IEEE*, Po-YiYeh, *Student Member, IEEE*, U-Ting Yeh, and Meng-Gu Huang, *IEEE TRANSACTIONS ON INDUSTRIAL INFORMATICS*, VOL. 9, NO. 2, MAY 2013.



Harshil Shah has received his B.E. degree in Electrical Engineering from Sardar Vallabhbhai Patel Institute Of Technology, Vasad(Gujarat), India in 2012. He is currently pursuing M.Tech degree in power electronics machines and drives, at the Institute of Technology, Nirma University, Ahmedabad, India. He has done this work in ELECTROTHERM (I) Ltd., Ahmedabad, India.